



PARMA 21D

NACELLE ÉLÉVATRICE ARTICULÉE ET TÉLESCOPIQUE DIESEL. HAUTEUR DE TRAVAIL: 21 MTS.

MODÈLE STANDARD:

- * Différents motorisations
- * Niveau électronique
- * Panier (1,8 x 0,8) m avec rotation 180°
- * Commandes proportionnels
- * Essieu oscillant
- * Traction 4x4
- * Direction 4 roues avec trois positions
- * Abaissement d'urgence sur panier et châssis
- * Limiteur de charge sur panier
- * Compte-heures
- * Stabilisateurs hydrauliques indépendants



Management System
ISO 9001:2008
www.tuv.com
ID 9105060482



PARMA 210



PARMA 210

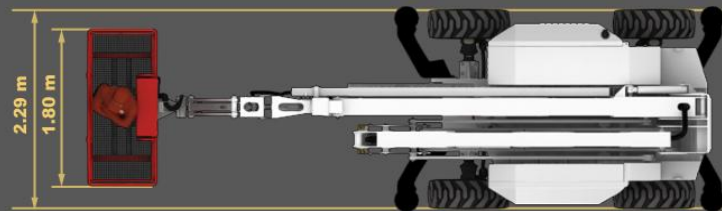
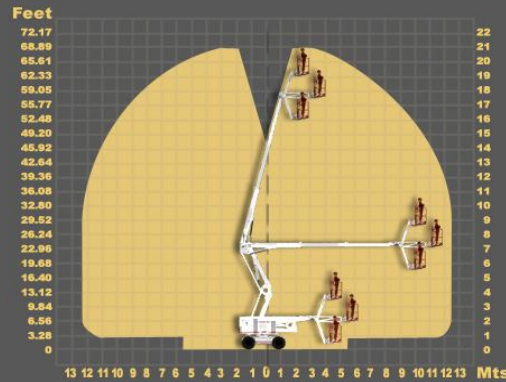
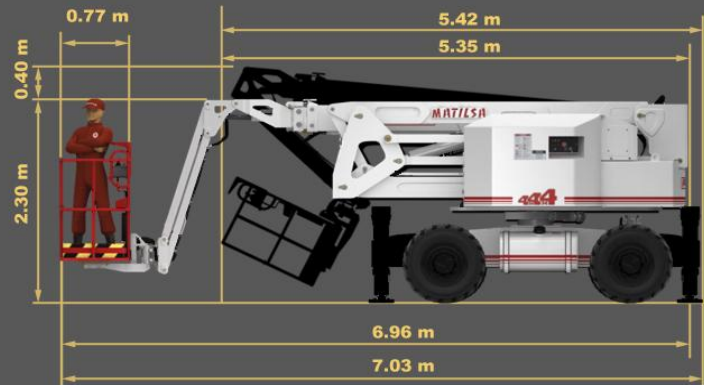

Accessoires disponibles

- 1 Prise de courant dans panier
- 2 Prise d'eau et d'air
- 3 Gyrophare
- 4 Nivellement automatique

